

9.0 End of Line Monitoring

An End of Line monitoring Diode or an End of Line monitoring Resistor can be connected across the 24V+ and 0 terminals. Resistor values for the End of Line will be determined by the customer with a minimum value of 1.2k Ω

10.0 Maintenance

Little or no maintenance is required during the normal working life of the product. The Ex-Tech Signalling Exd enclosures are resistant to most acids, alkalis and chemicals and have been designed to withstand severe weather conditions. However it is suggested that to avoid the possibility of a potential electrostatic charge build up, the exterior of the product is periodically wiped down with a clean damp cloth. At this point a visual inspection is recommended to ensure that the product is in good working order and no damage has been sustained during its normal operation.

11.0 Conditions for Safe Usage

i) This apparatus is suitable to be used only in ambient temperature as stated below:

Type	Ambient Temp
CP135	-40°C to +70°C

ii) Do not paint or change the surface finish of the unit. The coating applied by the manufacturer is Anti-Static & UV Stable.

Specific Condition for Use

Repairs of the flameproof joints must be made in compliance with the structural specifications provided by the manufacturer. Repairs must not be made on the basis of values specified in tables 1 and 2 of EN/IEC 60079-1.

Please contact Ex-Tech Signalling for further details.



INSTALLATION & TECHNICAL INFORMATION

PLEASE READ TO INSTALLATION



Type :			
CE 0470	II 2 GD	ATEX 13 NEMKO 1568X	
Ex d IIB+H2 T6 Gb	IP 66	IECEX, NEM 13.0038X	
Ex tb IIIC T85°C		CNEx 10.2121X	
T. amb: -40°C < Ta < +70°C	P	Watt	
	U	<input type="checkbox"/> VDC <input type="checkbox"/> AC50/60Hz	
	Serial N° :		
WARNING - DO NOT OPEN WHEN AN EXPLOSIVE ATMOSPHERE IS PRESENT			
Ex-tech Signalling SAS			
Ex-tech Signalling SAS, Champniers, France - www.ex-tech.no			

CP135 Series - (Explosion Proof Call Point)

Glass Reinforced Polyester

APPROVALS AND
CONFORMITIES



1.0 Introduction

The CP135 range is certified for use and installation in Zone 1 and Zone 2 with gas groups IIA, IIB+H, also Zones 21 and 22 for Dust. The unit carries a temperature classification of T4~T6. It especially applies to Oil & Gas, Offshore Platform, Chemical, Petrochemical, Refinery and Marine Industries etc. Enclosure material is UV and corrosion resistance GRP (Glass Reinforced Polyester). The manual call point has been designed for ease of installation and operation.

These call points are compatible for use with PLC, DCS & ESD systems via a 4-20mA output. They are intended for use in Fire Alarm Systems as a fixed addressable unit in potentially explosive atmospheres.

There are three types of Manual Call Points available with LED indication.

- **Red LED Indicator Only:** During normal operation the LED will not be on. The LED will only come on when the call point is activated by breaking the glass.
- **Green LED Indicator Only:** During normal operation the LED will be on. The LED will go off when the call point is activated by breaking the glass.
- **Red & Green Indicators:** During normal operation the Green LED will be on. The Red LED will come on when the call point is activated by breaking the glass. At this point the Green LED will go off.

7.0 Operation

In this model series, the units either come with a hinged flap (to prevent accidental activation of the unit) or no hinged flap.

In either case the glass must be broken with the hammer supplied with the unit to activate it (see diagram 3).

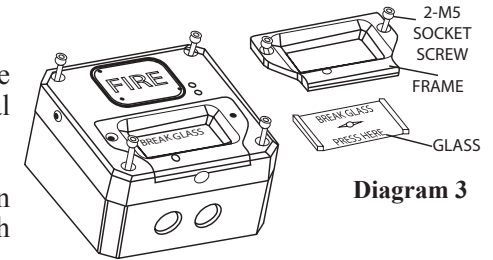

Diagram 3

Replacement of Glass

To replace the glass after operation of the unit, remove the small cover held in place by the two slotted screws. Take out the glass and remove any broken fragments from the unit. Place a new glass into the unit and replace the cover. (see diagram 3).

Testing the Unit

Insert the test key facility to the key hole located in the lower left corner of the cover. Then turn the key clockwise. The glass sheet will drop. This will simulate the breaking of the glass. Turn the key anti clockwise to reset the unit.

8.0 Cable Gland

Only cable glands approved for Exd applications can be used with Ex-Tech Signalling Explosion Proof Products, these must be suitable for the type of cable being used and also meet the requirements of the Exd flameproof installation standard EN 60079-14.

SAFETY WARNING

If units are used at high ambient temperatures, i.e. over +40°C then the cable entry temperature may exceed +70°C and therefore suitable heat resisting cable glands must be used, with a rated service temperature of at least 85°C.

If a high IP (Ingress Protection) rating is required, a suitable sealing washer must be fitted under the cable gland. Any unused cable entry holes must be closed with an Exd flameproof blanking plug, which must be suitably approved for the installation requirements.

6.0 Wiring

General Requirement

Ex-Tech Signalling recommends that all cables and cores should be fully identified (suggest using cable from 2.0 to 2.5 mm²). Ensure that all nuts, bolts and screws are secured. Ensure that only the right and certified cable glands are used and earthed correctly. Ensure that only the right and certified stopping plugs are used to blank off unused gland entry points.

Cable Connection

The cable connection is made to the 10-hole terminal block marked T1-T10 inside the enclosure (see diagram 2). Cable connection should be carried out in accordance with relevant technical requirements.

Remove Front Cover

CAUTION: Before removing the cover, ensure the power to call point is isolated. Unscrew the four (4) M5 retained Hex Head socket screws to open the cover.

Note: it recommended to open one blind plug to avoid internal vacuum in the unit

This will release the cover from the base and allow the cover to hang on the retaining wire strap. Before replacing the cover, check that the flameproof joints are clean and not damaged, the gasket is still retained in its groove (see diagram 2).

As lubrication / grease for the flameproof joint, a thin film of Acid free Vaseline (soap-thickened mineral oils) or mineral oil can be used, excessive lubrication/grease shall be removed before assembling.

Reinstall the cover in similar way, but operate in reverse manner as above.

Recommended Bolt Torque for M5 lid screws are 4.5Nm

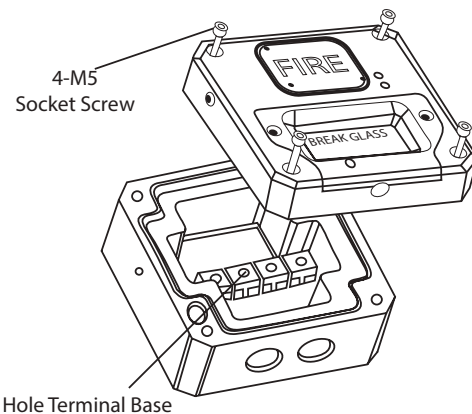

Diagram 2

2.0 Explosion-Proof Labelling

All products have a rating label with the following important information:

Product order no: eg CP135SNNYNNABRD (Refer to the datasheet for product order selection)

Input voltage: <30V DC / 6A or <250V AC / 11A Ex d IIB
Code: +H2 T6 Gb, Ex tb IIIC T85°C

Nemko ATEX Certificate No: Nemko 13ATEX 1568X

ATEX Mark:



IECEX Certificate: IECEX-NEM 13.0038X
Gas Group and Category: II 2GD
CE Mark: Mark No: 0470

Warning:

**DO NOT OPEN WHEN AN EXPLOSIVE
GAS ATMOSPHERE IS PRESENT**

Finished product serial no: ie.CP135-110140001

CP135- GRP Manual Call Point: **110-** France, **14-** Year, **0001-** Product serial number

3.0 Type Approval Standard

The Ex-Tech Signalling product range all have an EC Type Examination Certificate issued by Nemko and have been approved to the following standards:

EN 60079-0:2012 (IEC 60079-0:2011), EN-60079-1:2007 (IEC 60079-1:2007) EN 60079-31:2009 (IEC 60079-31:2008)

4.0 Zones, Gas Group, Category and Temperature Classification

The CP135 series products have been certified Ex d IIB+H₂ T6.

This means that the units can be installed in locations with the following conditions:

Area Classification:

Zone 1: Explosive gas air mixture likely to occur in normal operation.

Zone 2: Explosive gas air mixture not likely to occur, and if it does, it will only exist for a short time.

Gas Groupings: IIB+H₂.

Zone 21: Explosive dust air mixture likely to occur in normal operation.

Zone 22: Explosive dust air mixture not likely to occur, and if it does, it will only exist for a short time.

Equipment Category: 2GD

Temperature Range: $-40^{\circ}\text{C} < T_a < +70^{\circ}\text{C}$

5.0 Installation

General Requirement

The product must be installed in accordance with the latest EN60079-0 and EN60079-1 specification or the equivalent IEC specification. Product installation must be carried out in accordance with any local codes that may apply and should only be carried out by a competent electrical engineer.

Location

The location of the unit should be chosen with due regard to access. The unit should only be fixed to services that can support the weight of the unit.

Mounting

The product should be mounted on a vertical surface using four fixing holes in the base. The fixing holes are designed to fit M5 Allen Screw only. Use of stainless steel fasteners is recommended by Ex-Tech Signalling. The unit can be operated in any attitude. If you need a mounting plate, please contact Ex-Tech Signalling to ask for the mounting plate installation drawing (see diagram 1).

Diagram 1

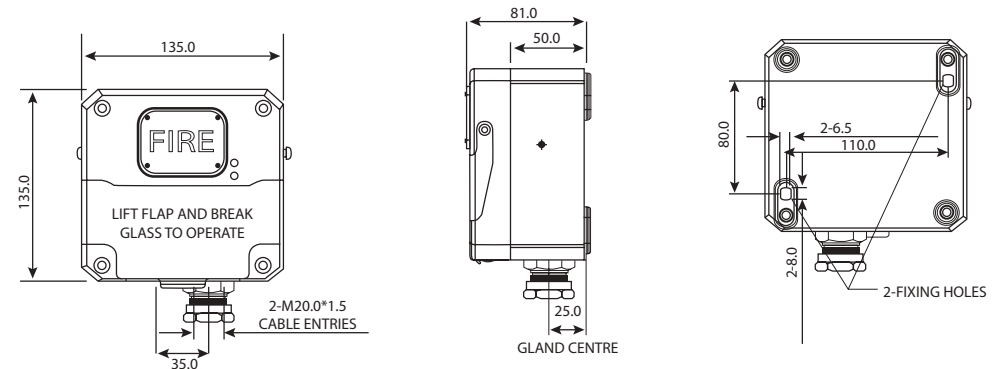

OMRON
V-154-1A5
Mini SWITCH

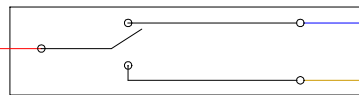

OMRON
V-154-1A5
Mini SWITCH

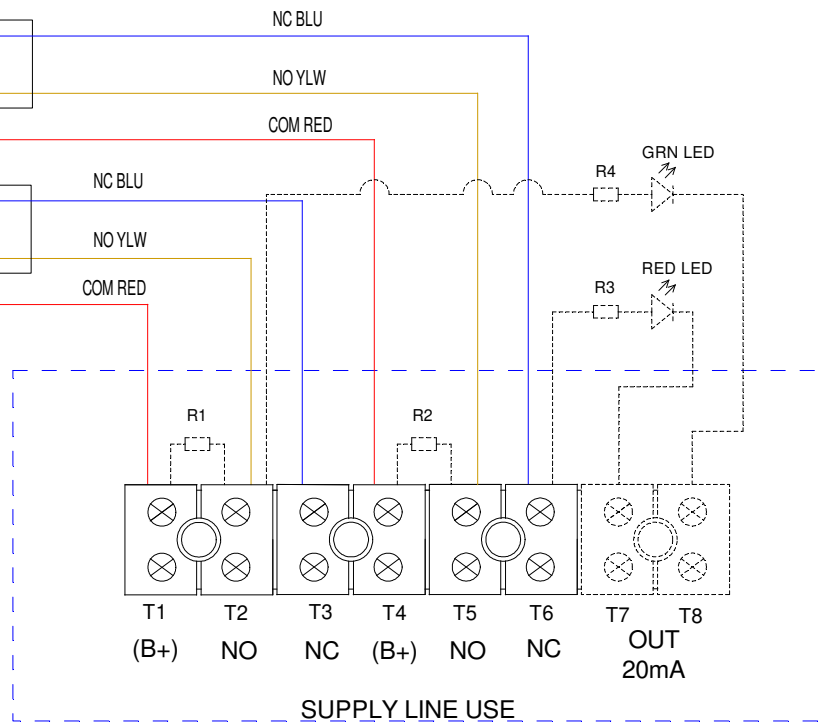
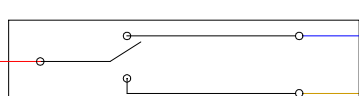

Attention Please:

R3 = 1.2K Ohm / R4 : 2.4K Ohm

Customize Project :

- Resistor R1 & R2
- RED LED
- GRN LED

01-08/03/2016	Mise à jour				Size : A3
00-17/09/2015	Creation				
Revision - date	Reason				
Material					
Treatment					
Specifications					
Drawing part WIRING DIAGRAM CP 135 DOUBLE SWITCH WITH LED OR RESISTOR		Scale :	1 : 1	Project / N° PO	Dossier
		Drawn by :	P. TRAUMAT	-	-
		Date :	17/09/2015	N° Drawing	Index Folio
				CP 135 DOUBLE SWITCH WITH LED OR RESISTOR	01 1/1

OMRON
V-154-1A5
Mini SWITCH

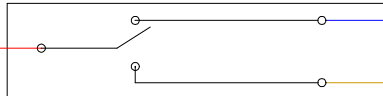

OMRON
V-154-1A5
Mini SWITCH

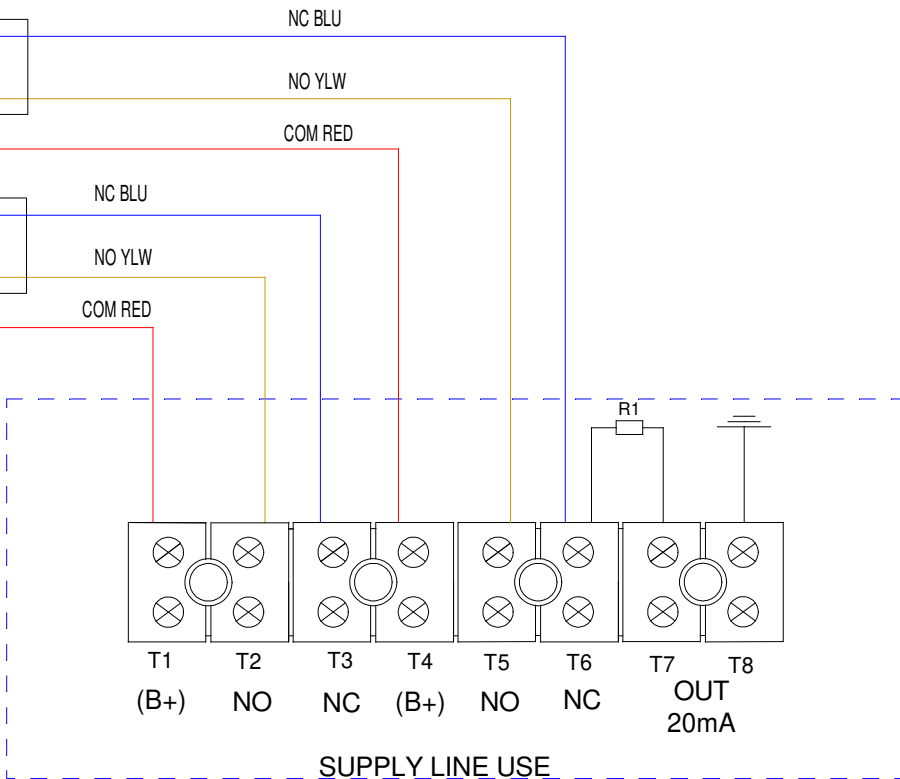
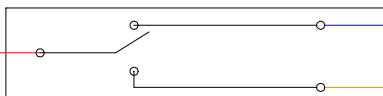

Attention Please:

R1 = 1.2K Ohm

01-08/03/2016	Mise à jour				
00-17/09/2015	Creation				
Revision - date	Reason				
Material				 Size : A3	
Treatment					
Specifications					
Drawing part		Scale : 1 : 1	Project / N° PO		Dossier
WIRING DIAGRAM CP 135 DOUBLE SWITCH WITH RESISTOR		Drawn by : P. TRAUMAT	-		-
		Date : 17/09/2015	N° Drawing		Index
		CP 135 DOUBLE SWITCH WITH RESISTOR		01	1/1

OMRON
V-154-1A5
Mini SWITCH

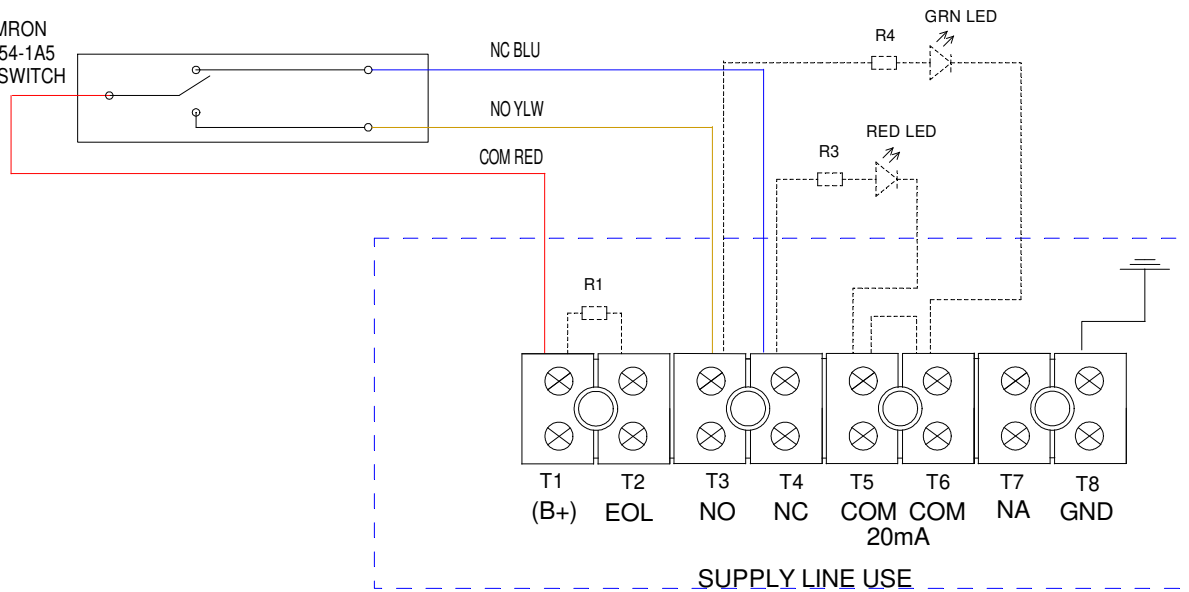

Attention Please:

R3 = 1.2K Ohm / R4 : 2.4K Ohm

Customize Project :

- Resistor R1
- RED LED
- GRN LED

02-08/09/2016	Mise à jour					
01-08/03/2016	Mise à jour					
00-17/09/2015	Creation					
Revision - date	Reason					
Material						
Treatment						
Specifications						
<p>Drawing part</p> <p>WIRING DIAGRAM</p> <p>CP 135 SINGLE SWITCH</p> <p>WITH LED OR RESISTOR</p>		Scale:	1 : 1		Project / N° PO	Dossier
		Drawn by:	P. TRAUMAT		-	-
Date:	17/09/2015	N° Drawing	CP 135 SINGLE SWITCH WITH LED OR RESISTOR		Index	Folio
					02	1/1



Size :
A3

OMRON
V-154-1A5
Mini SWITCH

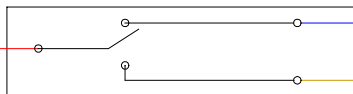

NC BLU

NO YLW

COM RED

OMRON
V-154-1A5
Mini SWITCH

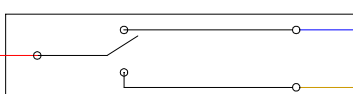

NC BLU

NO YLW

COM RED

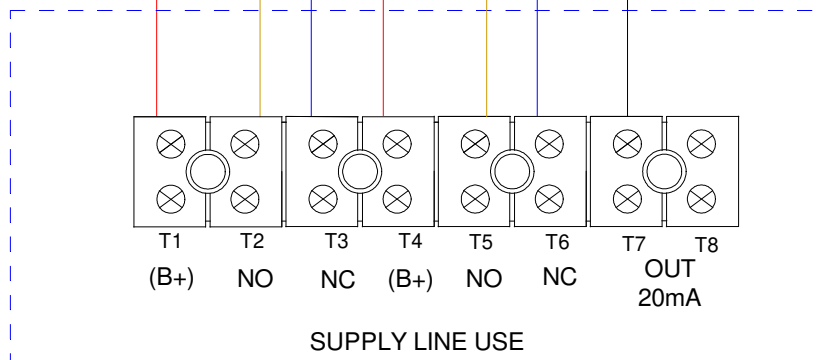

SUPPLY LINE USE

01-08/03/2016	Mise à jour			Size : A3	
00-28/09/2015	Creation				
Revision - date	Reason				
Material		Scale : 1 : 1		Project / N° PO	
Treatment		Drawn by : P. TRAUMAT		Dossier	
Specifications		Date : 28/09/2015		-	
Drawing part WIRING DIAGRAM CP_PB 125-135-150 DOUBLE SWITCH WITHOUT LED AND RESISTOR		N° Drawing		Index	Folio
		CP_PB 125-135-150 DOUBLE SWITCH WITHOUT LED AND RESISTOR		01	1/1

OMRON
V-154-1A5
Mini SWITCH

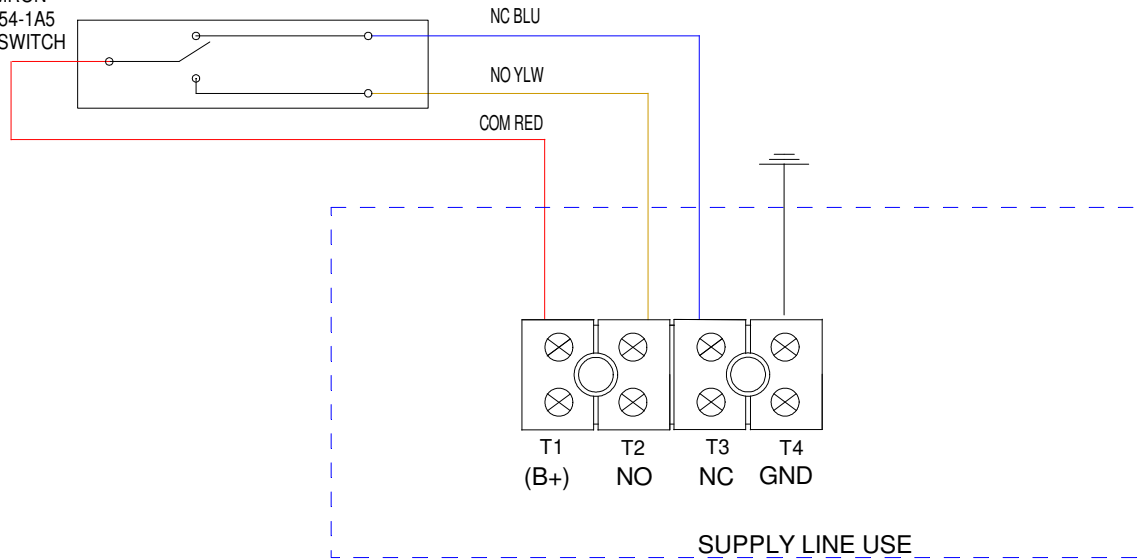

01-08/03/2016	Mise à jour				
00-28/09/2015	Creation				
Revision - date	Reason				
Material				 Size : A3	
Treatment					
Specifications					
Drawing part		Scale :	1 : 1	Project / N° PO	
WIRING DIAGRAM CP_PB 125-135-150 SINGLE SWITCH WITHOUT LED AND RESISTOR		Drawn by :		-	
		P. TRAUMAT		-	
		Date :	28/09/2015	N° Drawing	Index
				CP_PB 125-135-150 SINGLE SWITCH WITHOUT LED AND RESISTOR	01 / 1/1