

ALL DIMENSIONS IN MILLIMETRES U.O.S.

DO NOT SCALE DRAWING

IF IN DOUBT – ASK

6

POSITION E  
SOUNDER

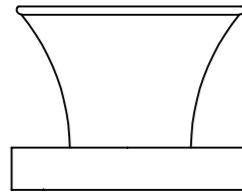

POSITION D  
BEACON

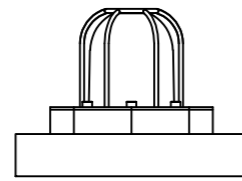

POSITION C  
BEACON

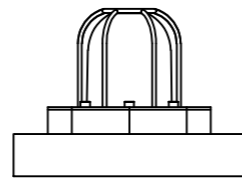

POSITION B  
BEACON

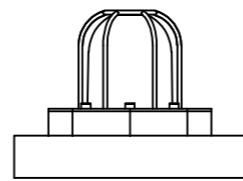

POSITION A  
JUNCTION BOX



5

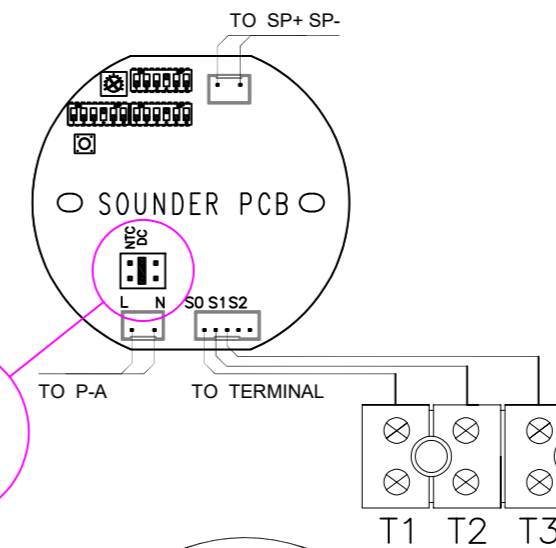
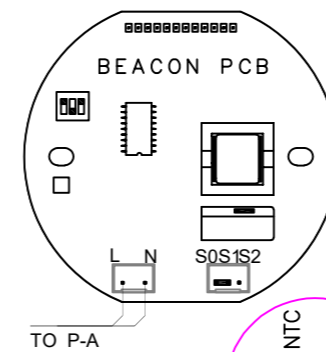
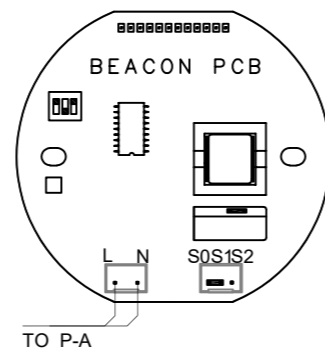
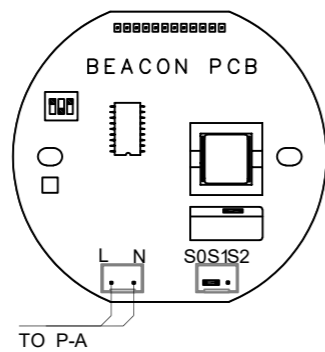

DC BUILDS ONLY:  
ADD SHUNT FOR  
BUILDS <24V

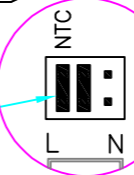

T1 T2 T3

4

3

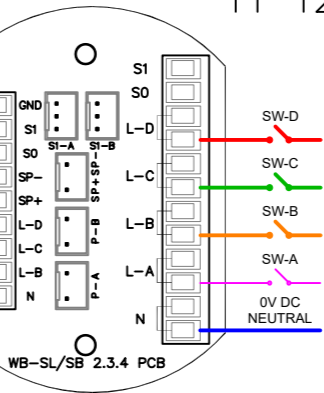
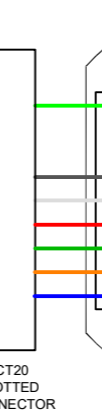
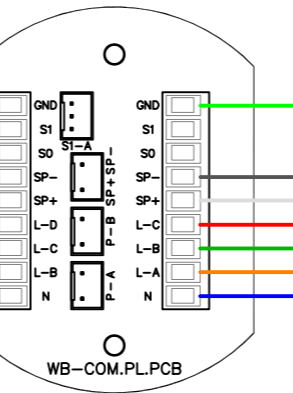
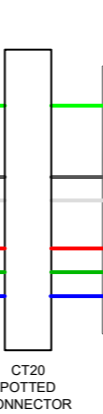
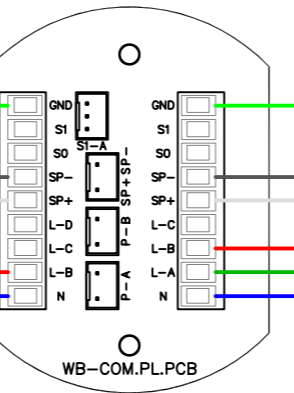
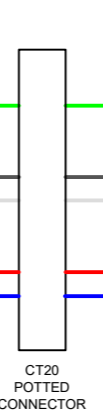
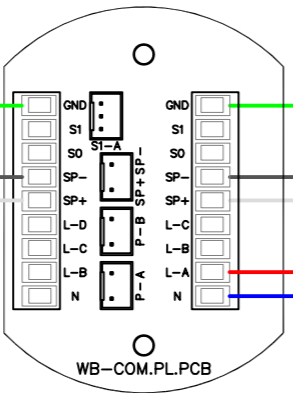
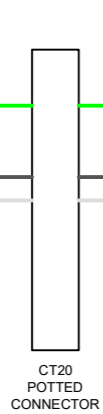
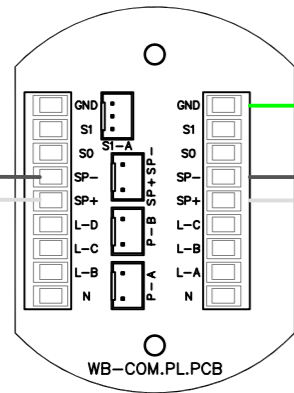

2

NOTE

1. BEACONS ARE PROVIDED WITH A 3 WAY JUMPER/SHUNT TO ACHIEVE STEADY STATE OPERATION. REPLACE THE SO/S1 2 PIN JUMPER/SHUNT WITH THE 3 WAY JUMPER/SHUNT IF STEADY STATE OPERATION IS DESIRED.

**WIRING AND FUNCTION**

FOR DC POWER SUPPLY:  
"L" EQUAL "B+", "N" EQUAL "0"

APPLY POWER SUPPLY:  
AC 100~230V OR DC 12V~48V TO  
"L"&"N"

CONNECT SW-A TO START  
SOUNDER

CONNECT SW-B TO START  
BEACON IN POSITION B

CONNECT SW-C TO START  
BEACON IN POSITION C

CONNECT SW-D TO START  
BEACON IN POSITION D

TO ADJUST THE SOUNDER TONE,  
PLEASE REFER TO THE  
INSTRUCTIONS IN THE PRODUCT  
TECHNICAL MANUAL

TO ADJUST THE BEACON  
FLASHING FREQUENCY, PLEASE  
REFER TO THE INSTRUCTIONS IN  
THE PRODUCT TECHNICAL  
MANUAL.

DO NOT SUPPLY AC OR DC  
POWER TO S0 /S1/S2

**Cable Selection**

Please select suitable size cable according to the distance between control room and the terminals and the quantity of equipments used.

Normal size for AC power supply cable L & N is 1.5mm<sup>2</sup>. Normal size for DC power supply cable L & N 2.5 mm<sup>2</sup>.

Please select the quantity of control cables (2 to 7) according to the actual requirement. Normal size for control cable is 1mm<sup>2</sup>.

1



|                  |  |                    |
|------------------|--|--------------------|
| DRAWN: KH        | FINISH: AS PARTS                           | MATERIAL: AS PARTS |
| DATE: 31/01/2024 | TITLE: EX-TECH WIRING DIAGRAM SB125/SB150  |                    |
| CHECKED: SB      | 4J SD-BC-BC-BC-JB                          |                    |
| DATE: 01/02/2024 | STANDARD WIRING NO RESISTOR(S) NO DIODE(S) |                    |

NO PART OF THIS DRAWING MAY BE REPRODUCED WITHOUT THE WRITTEN PERMISSION OF THE COMPANY

|           |         |   |
|-----------|---------|---|
| SCALE: A3 | DWG No. | 3 |
| NTS       | 2101/A3 |   |

A B C D E F G H I